

Before first using your new Brilliant LED Desk Lamp it is most important that you read and follow these instructions, even if you feel you are quite familiar with this type of product. Keep this document handy for future reference.

## For your safety

- Do not stare at an operating LED light source.
- The Adaptor is an LED driver. It must be used with this product only.
- This LED fitting has no user serviceable parts.
- This LED task lamp operates on safe Extra Low Voltage.
- Do not install in position where the fitting can be easily accessed by children or the infirm.

## Assembly Instructions

- Ensure the wall socket is switched off.
- Unpack the fitting carefully and place it on a flat surface. Do not plug the lamp into the wall socket yet.
- Place light on table or desk
- Plug barrel connector (1) into connector of light base. Ensure connection is firm.
- Plug the LED Adaptor (2) into the selected wall socket (W) and turn the mains power ON.
- Adjust the LED Lamp (3) to the desired position.
- Control light via touch button (4).

Note: 3 levels dimming function is operated from dark to bright.

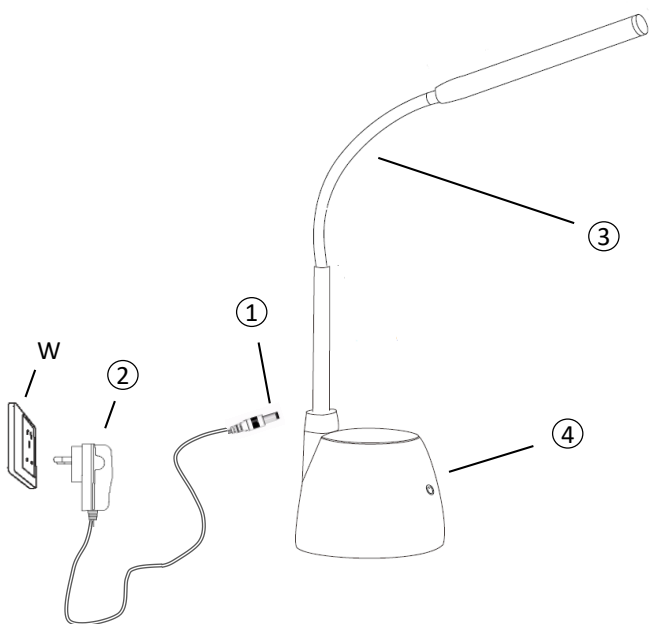

## SPECIFICATIONS:

<b>Fitting:</b>	LED Task Lamp
<b>LED :</b>	Dimmable Natural Colour Temperature LED Module is not replaceable
<b>Protection class:</b>	LED Adaptor Class II Task Light Class III
<b>Voltage:</b>	Input 220/240V~ 50Hz 0.1A Output 12V/0.36A

## Warnings

- During use the light head may become warm. It is recommended to exercise caution when touching light head assembly.
- Do not operate in a position where flammable materials can come into contact with the lamp.
- Do not look directly at the LED light source.
- Use it only with provided LED Adaptor (2) supplied.
- Do not operate in a position where children or infirm persons can access the fitting.

CAUTION: INDOOR USE ONLY

Made in China



# CASSIDY LED TASK LAMP 21695

## Warranty:

Brilliant Lighting warrants this product against defects in manufacture and workmanship for a period of 3 year from date of purchase or as specified elsewhere. For products used in non-domestic or commercial applications, Brilliant Lighting warrants this product for a period of 3 months from date of purchase. This warranty is only valid for products installed and operated within the guidelines specified by Brilliant Lighting, and within the correct operating voltage ranges as stated on the product's rating label.

Warranty does not include damage or loss arising from incorrect installation, operation or maintenance of this product, damage caused through modification, incorrect installation, service by unqualified or unauthorised personnel or lack of regular maintenance and cleaning. Proof of installation by qualified personnel may be required, e.g. Electrical Safety Certificate. Proof of purchase must be supplied with all warranty claims.

This warranty is provided in addition to any other rights and remedies of the customer under any law. In applications not intended for household, personal or domestic use, liability is limited to replacement or reimbursement of product only. Brilliant Lighting does not warranty the costs of removal or re-installation of this product or associated components.

*Our goods come with guarantees that cannot be excluded under the Australian Consumer Law. You are entitled to a replacement or refund for a major failure and compensation for any other reasonably foreseeable loss or damage. You are also entitled to have the goods repaired or replaced if goods fail to be of acceptable quality and the failure does not amount to a major failure.*

Any claim under this warranty must be made within the specified warranty period from date of purchase of this product. To make a claim under the warranty; at your own expense take the product (with proof of purchase – receipt or similar) to the store where you purchased the product or contact Brilliant Lighting at the address below.

This warranty is given by:

**Brilliant Lighting (Aust) Pty. Ltd.**

**ABN 37 006 203 694**

**956 Stud Road Rowville, VIC 3178**

**Phone: 03 9765 2555**

**Email: [warranty@brilliantlighting.com.au](mailto:warranty@brilliantlighting.com.au)**

**MADE IN CHINA**